

HELMACAB



CABLE DRUM HANDLING AND CABLE INSTALLATION

**TRANSPORT, STORAGE &
INSTALLATION RECOMENDATIONS
FOR HELMACAB CABLES**

2024

HELMACAB

GENERAL

This guide illustrates how damages to cables and cable drums can be avoided by correct handling and storage practices.

HANDLING

Drum flanges are marked to provide vital information to assist with the handling of the drums and installation of the cable. This information includes drum weight, a mark on the flange indicating the end of the cable, and an arrow indicating the rotating direction of the drum for rolling or transportation. If the handling is done correctly, the drum will protect the cable from damages.

The forks of the forklift must be longer than the width of the drum, so that the lagging is not damaged. Always raise the forks of the forklift sufficiently above the ground when lifting the drum.

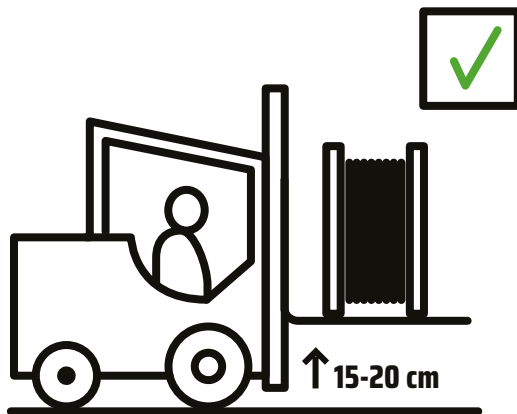

Raise the forks of the forklift sufficiently (15-20 cm) above the ground.

Insufficient lifting height may cause the drum to be dragged on the ground and eventually get damaged or dropped off the forks, especially if the ground surface is uneven.

The drums may be placed and stacked on pallets to make moving them easier and safer.

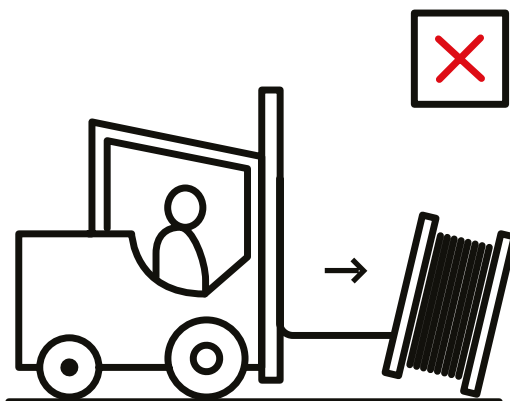

Never push the drum with the forklift.

STORAGE

Cable drums shall be stored properly. Improper storage conditions can easily cause damage to cable drums or the actual cables. Cable ends shall be sealed with caps to prevent ingress of water. The caps must be protected to avoid any mechanical risk and exterior shocks. Always check drums before moving them.

Drums shall be stored on a level and firm surface (e.g. timber baulks, flange edges) standing upright and strapped/wedged securely into place. Do not store the drum with the flange flat on the ground.

Drums shall not be standing in water or be stored in continually damp conditions. Storing drums in these conditions is likely to result in timber rot or collapse of the drum to the point where the cable will end up resting on the ground. Any of these outcomes will make later installation of the cable more problematic or impossible.

Recommended cable storage temperature:

-40 °C - 50 °C

Handling temperature:

-15 °C - 45 °C

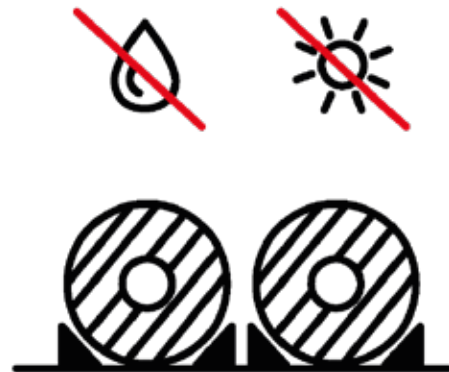

Cables with coloured outer sheaths shall not be stored in direct sunlight to prevent fading.

Cables shall be protected against direct sunlight with suitable protective packaging, such as plastic sheeting.

If the cable is used progressively (partial lengths are cut and used), the exposed cable end must be immediately sealed with a new end cap. Heat shrinkable end caps are recommended.

PACKING

Cable drums shall be packed correctly for transportation before shipping. The packing consists of:

- Plastic foil wrapped over the cable layers and affixed with adhesive tape
- Cladding boards attached with plastic or steel strap (optional). Do not tighten the strap to avoid damaging the cable.

HELMACAB

If the cladding boards need to be attached to the flanges of the drum with nails, the nailing shall be done making sure the nails hit the middle of the flanges, not damaging the outer cable layers.

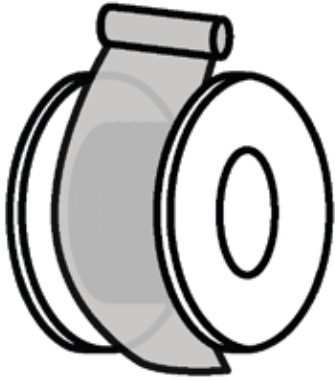

Plastic foil is wrapped over the cable layers and affixed with adhesive tape.

TRANSPORT

The bigger cable drums shall be loaded in the container or transportation vehicle in vertical position, i.e. standing up.

Secure the drums firmly, the round shaped cable drum rolls easily. Make sure each drum is secured in place with stoppers/wedges to tie down the front and rear of the drum, to prevent moving during transportation and storage.

Cable drums with diameter ≤ 1.2 m:

Horizontal position can also be used and the drums can be stacked.

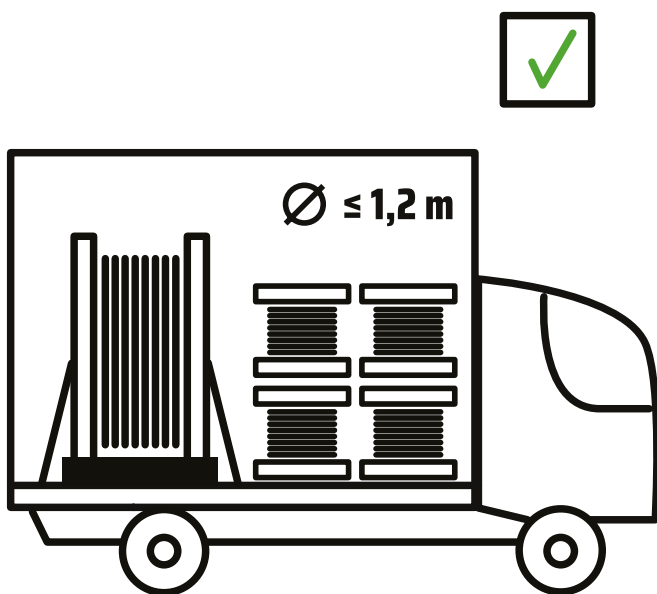

Secure the drums with a combination of wedges and transportation straps to tie down the drums during transportation. Drums with $\varnothing \leq 1.2$ m can be stacked.

LOADING AND UNLOADING

Main dangers are the invisible damages that lead to unusable cables. Therefore basic guidelines need to be followed. The cable itself must always be protected. Cable or drum, damaged by handling etc. must be checked before use.

The unloading and handling shall be done carefully using correct lifting equipment. To avoid damage when handling the drum with a forklift, place the drum vertically on the forks and only lift the drum from the flange side. Never let the drum fall during unloading.

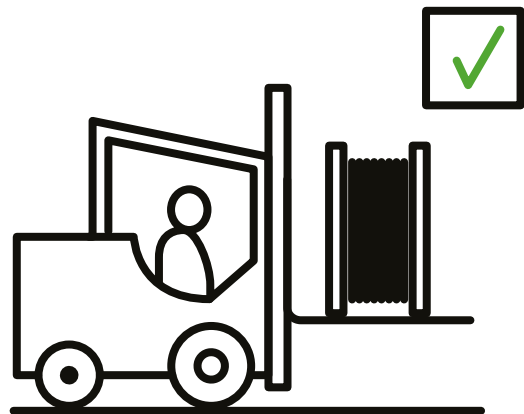

Lifting cable drums with a forklift is only allowed from the flange side.

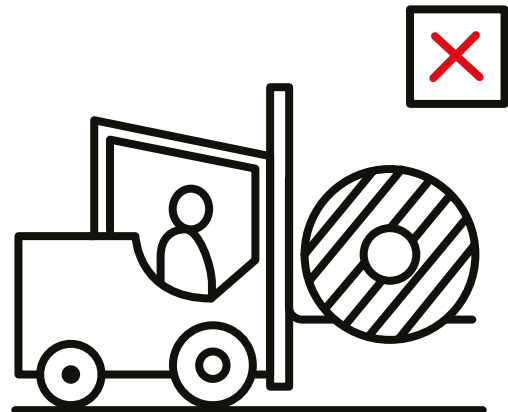

Never touch the cable or its protective cover with the forks.



Never let a drum fall during unloading.

HELMACAB

Inspect the cables when they arrive on site. Check the condition of the end caps of the cables and the lagging (a break in the wooden lag could tear and damage the outer sheath of the cable).

If the cable drums show signs of damage from handling and/or storage, any warranty obligation given for the cable drums and any subsequent problems resulting from it, are null and void.

INSPECTION

Drums, cables and delivery documents must be inspected upon the arrival of the products. The packing list and product order have to match the received products. In case of document flaws contact the nearest Helmacab representative to assess the situation and advise an appropriate solution.

The received drums should be carefully inspected to ensure that no damage occurred during transportation. If any damage is discovered on the drum, it is advisable to also check the cable for damages. It is essential to inform your Helmacab representative if any cable or severe drum damage is found. The damage shall be documented before moving the drum in order to demonstrate the situation properly.



Drums, cables and delivery documents must be inspected upon the arrival of the products.

LONG-TERM CABLE STORAGE

Always inspect the drum before moving it from long-term storage. Transport vibrations and movement, weathering or environmental damage can cause changes in the drum, and an assessment of the state of the drum is necessary.

In alternating dry and wet weather, or consistently dry and hot weather, the wooden sections of the drum can shrink and the whole drum can become unstable and cause damage to the cable when moving the drum. Therefore, the transverse bolts must be tightened with a torque wrench before the drums are moved, to prevent the drums from collapsing.

To ensure the bolts stay tight they must also be re-tightened during cable installation.

Note that timbers of the drum flanges and barrels that have shrunk are also likely to have loose nails, but they are harder to fix than bolts. Apply caution and vigilance during the cable unwinding to identify loose nails and therefore reduce possible damage to the cable.

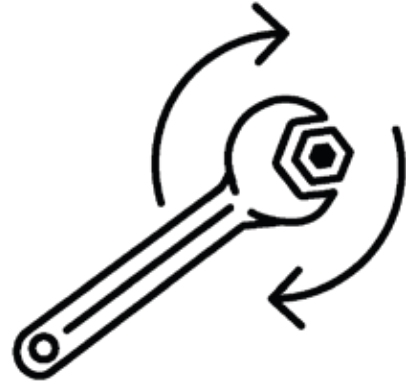

The transverse bolts must be tightened with a torque wrench before the drums are moved, and re-tightened during cable installation to ensure the bolts stay tight.

If the cable ends are accessible, it is recommendable to inspect the condition of the end caps. The end cap is designed to prevent the ingress of water. If the cap or seal has been absent for a long time (more than one month); or the cable end faces up toward the sky; or the end cap has been absent during periods of rain; or any form of cable end deterioration/ageing/swelling/ or soiling is observed; it is recommended that the cable end be cut back 300 mm and re-examined for presence of moisture. If moisture is found, cut back further, and apply a new end cap to the cable end, ensuring a tight seal to the cable outer layer.

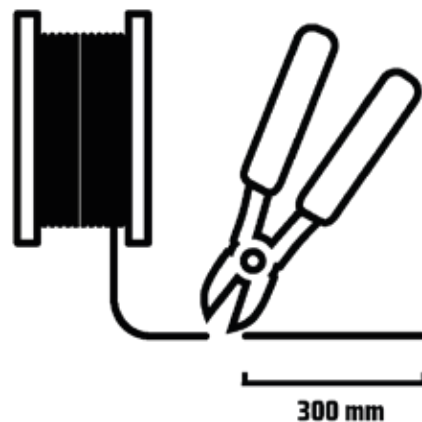

If the end cap has been absent or it is clearly damaged, cut 300 mm from the cable end and apply a new end cap.

HELMACAB

INSTALLATION GUIDELINES FOR HALOGEN-FREE SHIPBOARD CABLES

GENERAL CONSIDERATIONS

This document presents the guidelines for installing Helmacab halogen-free shipboard cables. The guidelines are based on the standard IEC 60092-352-1 and on the experience from users.

Because the requirements of the classification societies may differ, it is strongly recommended to get installation procedures approved by the classification society involved in each project.

CABLE SELECTION

Helmacab halogen-free cables can be installed outside on open deck. If the cable will be exposed to heavy direct sunlight, black outer sheath colour is recommended. Power and control cables with rated voltage 0,6/1 kV have a black outer sheath as standard. Other cable types are available in black on request. Another option for colour is to paint the cables with water solvent paint.

CABLE PULLING

Only cables of same size should be pulled at the same time. If different sizes are pulled at the same time, the small cables may get damaged.

When pulling big cables, it is recommended to use rollers, especially if the cables are pulled with the help of winches.

Never cross the cables when pulling to avoid abrasion damage to the outer sheath at crossing point.

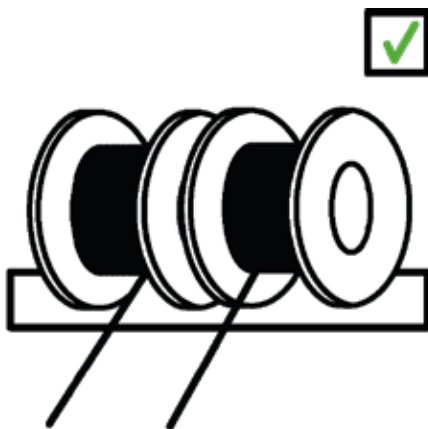

Only pull same size cables together.
Use rollers when pulling big cables.

The number of cables to be pulled at the same time is determined by the installation conditions at site: distance to be pulled, open space available for looping the cable at intermediary drawing stations, and the routing of cables (number of bends and number of corners).

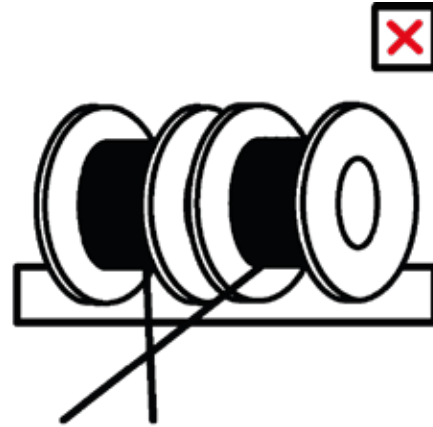

Cables should not be pulled crossing each other to avoid abrasion of the sheath at the crossing point.

PROTECTION OF CABLES DURING BUILDING OR REPAIR

Against welding sparks

When welding close to cable drums or already installed cables:

- The drum and cable should be protected against the welding sparks e.g. with a fire blanket or with a protection plate. A fire blanket is found to be very practical and easy to use.
- Same methods can be used for the protection of installed cables.

Against abrasions on outer sheath

- Temporary cables used at the site (e.g. for welding and lighting) should not be pulled crossing already installed cables to avoid abrasion of the sheath at the crossing point.

HELMACAB

MINIMUM CABLE BENDING RADIUS

The minimum bending radius during installation and for fixed installation shall be according to the following table.

UNARMoured AND UNSHIELDED CABLE TYPES

(LKM-HF AND LKMM-HF)

Diameter range	During installation	Fixed installation
≤ 25 mm	6 x Ø	4 x Ø

UNARMoured AND UNSHIELDED CABLE TYPES

(LKM-HF, LKMM-HF AND LKM-FRHF)

Diameter range	During installation	Fixed installation
> 25 mm	9 x Ø	6 x Ø

ALL OTHER CABLE TYPES

Diameter range	During installation	Fixed installation
All sizes	9 x Ø	6 x Ø

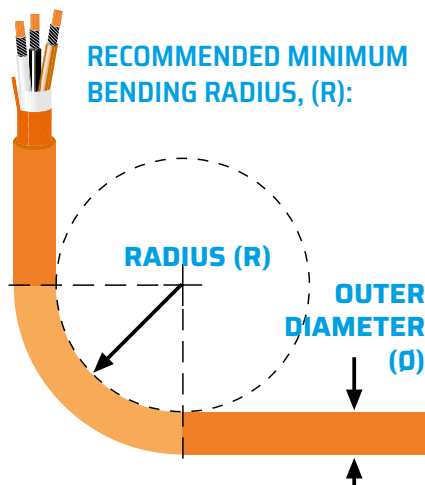

MINIMUM INSTALLATION AND OPERATION TEMPERATURE

Minimum installation temperature for all cable types:
-15 °C.

Lowest operation temperature for all cable types:
-40 °C.

CABLE FIXING

Cables shall be fixed by means of clips, saddles or straps of suitable material, which if ignited will not contribute to any spread of flame along the cables or insulated wire. The material shall have a surface area sufficiently large, and shaped so that the cables remain tight without their coverings being damaged. (IEC 60092-352 Clause 3.19)

As a guideline, the following recommendations can be given for straps (partly from Panduit website):

Strap length (mm)	Strap width (mm)	Max. Ø of cable bunch (mm)
102	2.5	22
142	3.5	35
188	4.8	48
292	4.8	75
371	7.6	102
510	12.7	130
718	12.7	200

The distances between supports shall be chosen according to the type of cable and the probability of vibration. It shall not exceed 400 mm for a horizontal cable run where the cables are laid on cable supports in the form of tray plates, separate support brackets or hanger ladders. The spacing between the fixing points may be up to 900 mm, provided that there are supports with maximum spacing as specified above. This exemption shall not apply to cable runs along weather decks, when the cable run is arranged so that the cables can be subjected to forces by water washing over the deck. (IEC 60092-352 Clause 3.19)

When designing a cable support system for single core cables, consideration shall also be given to the effects of electrodynamic forces developing in the occurrence of a short circuit. The distances between cable supports given above are not necessarily adequate for these forces. Cables with Class 5 conductors may require additional support to prevent sagging. (IEC 60092-352 Clause 3.19)

The requirement above can be fulfilled by fixing the cables to each step of the cable tray or at maximum 400 mm intervals.

HELMACAB

Fixed installation must be used when the cable is protected with a heat shrinkable sleeve. If there is a possibility that the cable outside the heat shrinkable sleeve may vibrate or move, the sleeve must be long enough to be fixed on both ends.

REPAIR INSTRUCTIONS FOR HELMACAB HALOGEN-FREE SHIPBOARD CABLE OUTER SHEATH

If the cable has a damaged outer sheath, screen and insulation:

- The whole cable has to be replaced.

If the cable has damages only (a hole or similar) on outer sheath, it can be repaired according to following instructions:

- Clean the damaged cable surface with a suitable cleaning agent.
- Grind the cable surface with sandpaper.
- Clean the grinded cable surface from sliver.
- Wind tape (Scotch 70) around the cable with a little extension. Ensure the winding has 20-50 % overlap.
- Set a shrink-on sleeve of flame retardant material over the taped length with 10 % overlap. Ensure that the diameter of the shrunk sleeve is correct.
- Heat up with a hot-air blower, not with a fire blower. Start heating from the middle and work towards the ends.

If the cable has deformation but the outer sheath of the cable is undamaged:

- It may be difficult to determine if there is damage inside the cable.
- It is difficult to know if the screen wires have deformed the cable insulation. The screen wires may have damaged the cable insulation and the insulation wall thickness may have decreased.
- The characteristics will not be the same as for an undamaged cable.

If unsure, please contact the local representative of the classification society.



SPECIAL INSTRUCTIONS FOR LIGHT CABLES

Light cables are designed for applications where low weight and small size are required. Compared to standard cables, these cables are manufactured using smaller insulation and outer sheath wall thickness. Light cables include cable types LKM-HF L, LKSM-HF L, RFE-HF L, and LKSM-FRHF L.

All the instructions in this document are also applicable to Light cables. In addition, using special caution is recommended in handling Light cables during cable pulling due to smaller outer wall thickness.

IEC 60092-352 Ed.3.0 2009-9



HELMACAB

INSTALLATION GUIDELINES FOR ELECTRICAL AND OPTICAL FIRE-RESISTANT CABLES

GENERAL CONSIDERATIONS

Installation procedures must adhere to guidelines outlined in standard SFS 6000, or other relevant local electrical installation standard, to ensure safe and proper installation. Installation of fire-resistant Marine cables shall follow rules and requirements of IACS/IMO/SOLAS.

Only trained and skilled electrical technicians are permitted to conduct cable installations. Regulatory authorization is required for all installations.

MATERIALS AND EQUIPMENT

All installation materials and equipment must be fire-resistant. For example, cable racks or trays must be fabricated from steel. Racks or trays made of aluminium do not withstand heat as well as steel. The choice of installation materials and equipment is at the discretion of the installer; Helmacab does not specify the use of specific manufacturers' materials. All installation accessories must be compatible with the cables.

TECHNICAL SPECIFICATIONS

Refer to the official Helmacab company website helmacab.com for the technical specifications of the cables. Maintain a recommended bending radius specified in above mentioned technical specifications during the installation process.

Note! The bending radius factor can vary between different cable types.

SPECIAL CONSIDERATIONS

When vertically installing fire-resistant cables, it is crucial to account for the fact that in the event of a fire, the tensile strength of the copper conductor significantly reduces due to heat exposure. Additionally, all supporting materials (insulation and sheath) are combustible. Therefore, the maximum permissible height for conduit installations is 3.5 meters, and cable fastening must be secured with appropriate fixtures that ensure sufficient strain relief. An example of such fixtures includes WUM bracket hangers.

APPLIED STANDARDS

FIRE TEST STANDARDS

BUNDLE	IEC 60332-3-22 (EN 60332-3-22)
SINGLE CABLE	IEC 60332-1 (EN 60332-1)
FIRE RESISTANCE	IEC 60331-21 IEC 60331-25 (optical cables) or IEC 60331-1 / IEC 60331-2
SMOKE EMISSION	IEC 61034 series (EN 61034 series)



Adhere to guidelines to ensure safe and effective installation of fire-resistant cables. For inquiries or further information, contact our technical support team.

HELMACAB

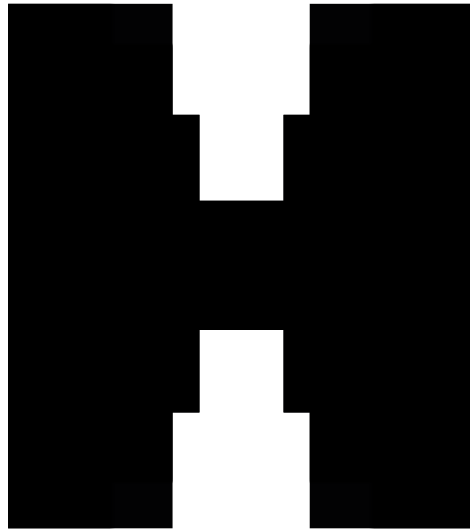

helmacab.com

HELMACAB OY

Lakimiehenkatu 4
FI-20780 KAARINA, FINLAND

Lasitehtaankatu 12
FI-10960 HANKO, FINLAND

Tel. +358 2 410 8700
customer.care@helkamabica.fi

HELMACAB Shanghai Co., Ltd.

Plot 1-2, MinHang Export Processing Zone
No. 3111 Huan Cheng
West Road
Fengxian District
Shanghai 201401, CHINA

Tel. +86 21 3365 5333
sales@helkamabica.cn

HELMACAB HOLLAND B.V.

Griendweg 72
4209 DB Schelluinen,
THE NETHERLANDS

Tel. +31 183 617 109
info@helmacab.nl

